

REPLACEABLE PAD OVERVIEW

Rest Pads & Gripper Pads



Solid Carbide

High impact carbide pads. Can be brazed or bonded into place.

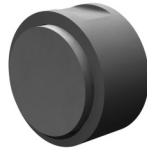

Carbide Tipped

Constructed with a high impact carbide pad brazed to a heat treated alloy steel body. Mounts with tapped hole or a flat on the outside diameter for set screw mounting.

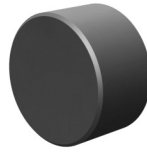

Hardened Steel

Made from 8620 steel, carburized and hardened to Rc 58/60 .050" case with black oxide finish. Mounts with tapped or counter bored hole.

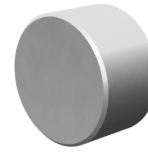

Non-Marring Delrin

Manufactured from white Delrin. Mounts with tapped or counter bored hole.

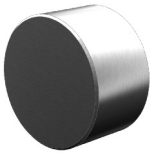

Stainless Steel

The pad is made from 17-4 stainless steel, hardened to Rc 43/46. Mounts with tapped or counter bored hole.

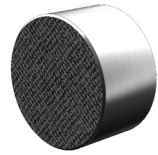

Abrasive Diamond Surface

The abrasive surface is permanently fused to a 17-4 stainless steel pad, hardened to Rc 43/46. The surface texture is comparable to a 100 grit abrasive. Mounts with tapped or counter bored hole.

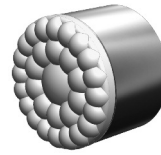

Sof-Top® Urethane Surface

The urethane surface is permanently bonded to a 300 series stainless steel pad. The urethane provides excellent protection against damage on delicate work surfaces. They are available in two durometers. Tapped hole mounting.

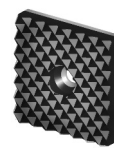

GP-Series Rubber Gripper Pad

Black nitrile rubber is molded to a malleable aluminum backing that can be formed to round or sharp corners. Highly customizable and easily replaceable for industrial grade contact wear points in automation and positioning applications.

TOOTH PATTERN SPECIFICATIONS

Angle Grippers

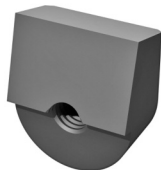

Smooth



4 Point

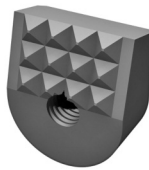

Fine

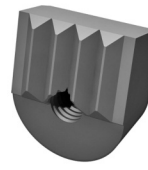

Straight

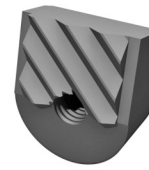

Angular Straight

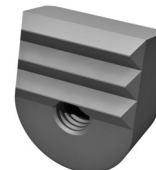

3 Point /
90° Straight

Round and Square Grippers

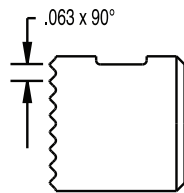

Super Fine
"SF"

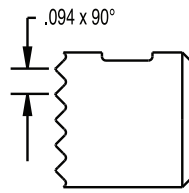

Extra Fine
"EF"

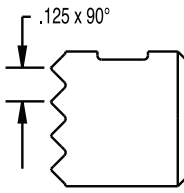

Fine

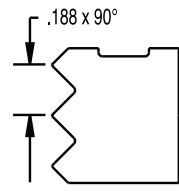

Coarse

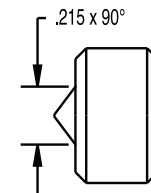

Single Point

Diamond
Serration
Pattern

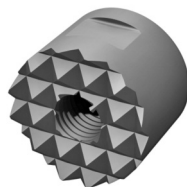

Straight
Serration
Pattern
"SS"

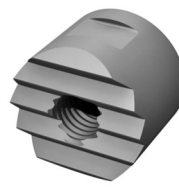

REPLACEABLE PAD OVERVIEW

Serrated Gripper Pads

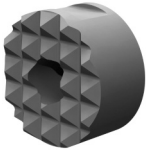

High Speed Tool Steel

Round, square, edge, and angle grippers manufactured from M-2 high speed tool steel, hardened to Rc 60/62 with black oxide finish. Mounts with tapped hole, counter bored hole or a flat on the outside diameter for set screw mounting.

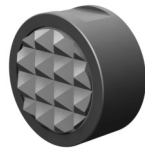

Carbide Tipped

Round, square, and angle grippers constructed with a high impact carbide pad brazed to a heat treated alloy steel body. Mounts with tapped hole or a flat on the outside diameter for set screw mounting.

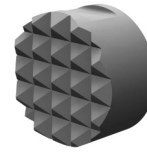

Solid Carbide

Round and square grippers manufactured from high impact carbide in a solid gripper pad or as a solid gripper body with a threaded brazed-in steel insert. Mounts with tapped hole or a flat on the outside diameter for set screw mounting.

GRIPPER PAD AND REST PAD MOUNTING APPLICATIONS AND SPECIFICATIONS

Below are some of the more common mounting applications for fixed grippers, rest pads and carbide pads shown in this catalog.

Round or square grippers and rest pads with tapped blind-hole or through hole tap.

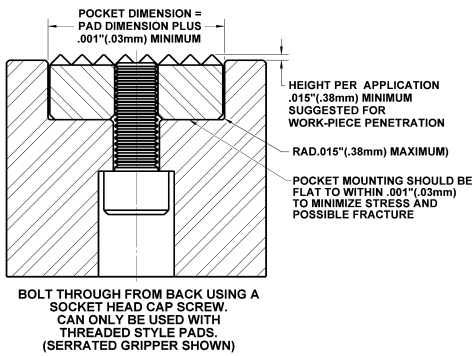

Round or square grippers and rest pads with counter-bored hole.

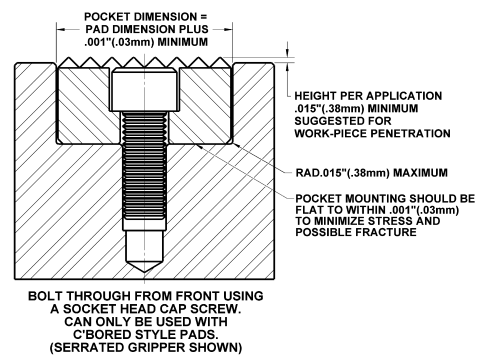

Round grippers with flat on the O.D. for set screw mounting, or square gripper.

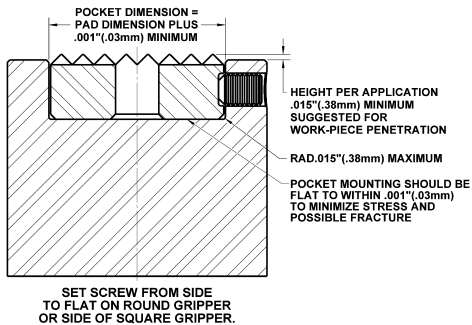

Round or square grippers with through tapped hole.

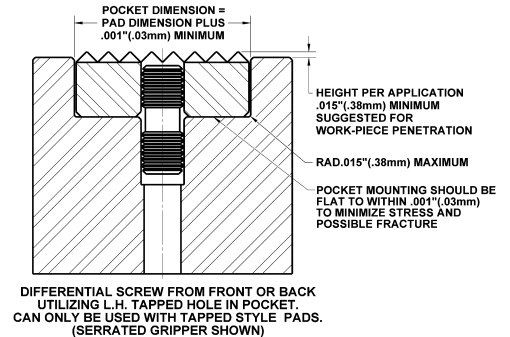

Round or square carbide pads.

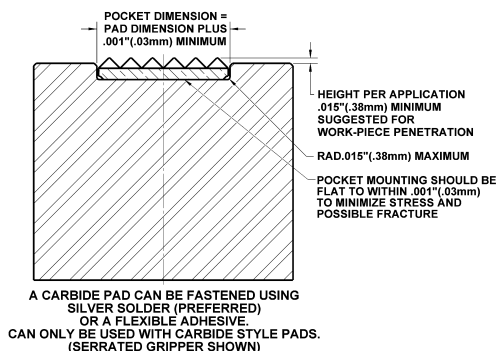

Counter-bored edge grippers.

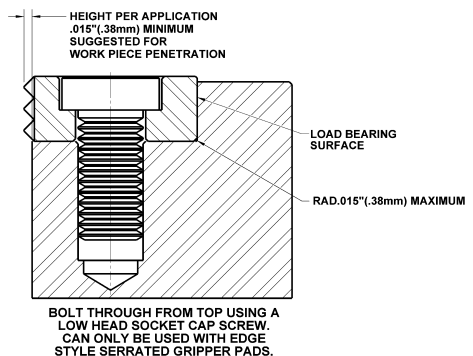

THREADED ADJUSTABLE GRIPPER OVERVIEW

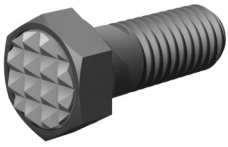

Carbide Tipped

Round and Hex head styles constructed with a steel body. Carbide tipped for positive holding and wear resistance.



High Speed Steel

Manufactured from M-2 high speed tool steel, hardened to Rc 55/58. Internal hex on backside allows for positioning adjustment.



AdjustaGrip™

The gripper pad can be replaced when it becomes worn. Uses tapped through hole grippers.



AccuGrip™

Designed to fit within chuck jaws to adjust concentricity. Carbide tipped for wear resistance.

SWIVOTS® & THRUST SCREW OVERVIEW

Swivots® & Thrust Screw Replaceable Balls



Sof-Top™ Urethane Surface Cone

The urethane surface is permanently bonded to a stainless steel ball. Provides excellent protection and non-slip grip on finished and other delicate surfaces. Available in two durometers.



Non-Marring Delrin Cone

Made from white Delrin plastic. Non-marring and non-staining for finished and other delicate surfaces.



Stainless Steel Cone

Made from stainless steel. Provides excellent corrosion resistance in harsh environments.

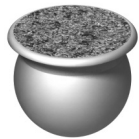

Abrasive Diamond Surface

The diamond surface is permanently bonded to a stainless steel ball. The surface texture is comparable to a 100 grit abrasive. Provides excellent grip on a variety of surfaces with minimal penetration.



High Speed Steel -Serrated

Made from hardened M-2 high speed tool steel. Available in 3 different serration patterns.



Non-Marring Delrin

Made from white Delrin plastic. Non-marring and non-staining for finished and other delicate surfaces. Available with different stand off heights.

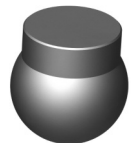

Flat Tool Steel

Made from hardened M-2 high speed tool steel. Heat treated to Rc 60/62. Available with different stand off heights.



Round Delrin Ball

Made from white Delrin plastic. Non-marring and non-staining.

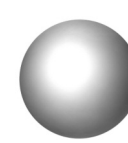

Round Stainless Steel Ball

Made from 440c stainless steel. Heat treated to Rc 58/62.

SWIVOTS® & THRUST SCREW OVERVIEW

Replaceable Pad Style Swivots®

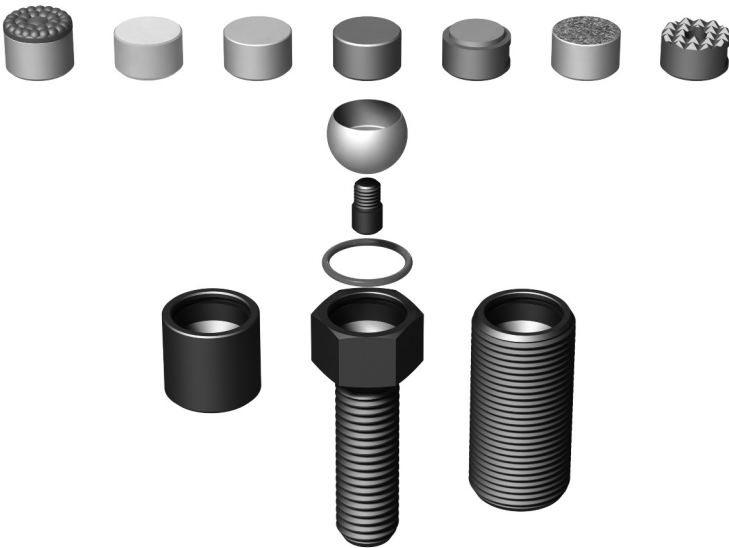

- Unique design allows the pad and ball cup to swivel, tilt, clamp, grip, hold position and secure a work piece.
- The internal ball cup allows the pad to rotate 360 degrees and tilt at varying degrees from center.
- Interchangeable parts speed setups and changeovers.
- O-ring holds the ball in place and keeps out dirt and other contaminants.
- Replaceable pad design allows for easy change out when the pad is worn or a different contact surface is required.

Replaceable Swivel Ball Style Swivots®



- The unique design of the Swivots prevent the ball from exceeding the specified degree of swivel which stops the ball from rolling over in the housing.
- The replaceable ball can be changed when it is worn or another contact surface is required.
- The ball is held in place with a Viton o-ring which allows for smooth movement and keeps out dirt and contaminants.
- The replaceable balls are available in several different styles to meet a wide range of workholding and positioning applications.

Replaceable Swivel Ball Style Thrust Screw Assemblies

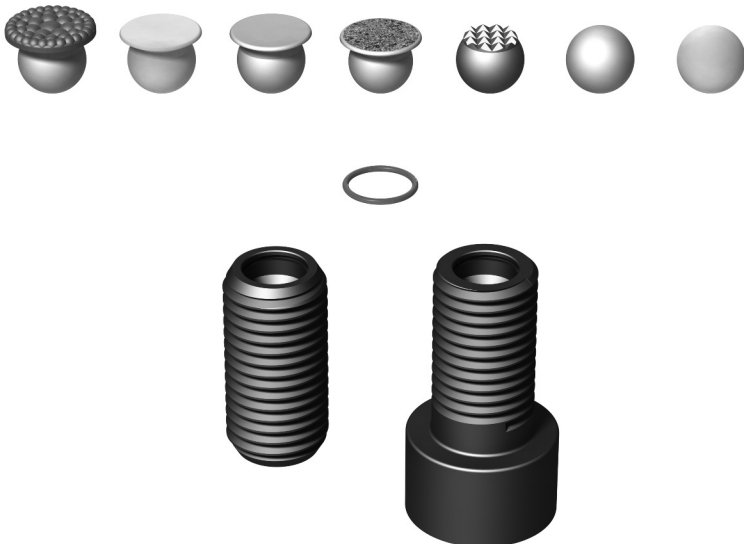

- The free floating ball design allows the thrust screw to continue rotating while the ball remains stationary against the contact surface.
- They are ideal for holding and positioning irregular shaped or contoured work pieces.
- The different housing styles allow for a variety of mounting options.
- The ball is held in place with a Viton o-ring which allows for smooth movement and keeps out dirt and other contaminants.