

# BJ130-B1

## HOOK-CLAMP ASSEMBLIES (Flanged)

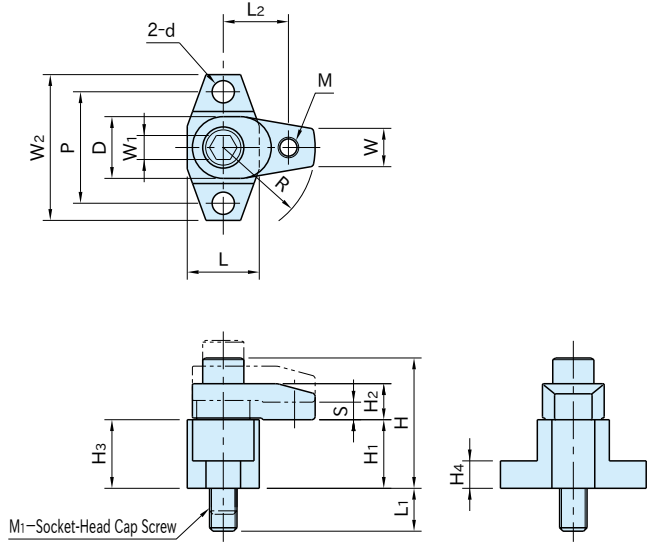

Clamp Body	Holder
SCM435 steel Quenched and tempered Black oxide finish Precision ground	S45C steel Black oxide finish

Part Number	H <sub>1</sub>	S (Clamping Stroke)	M	L <sub>2</sub>	R	W <sub>2</sub>	L	M <sub>1</sub>	L <sub>1</sub> (max)	d	H <sub>4</sub>	P
<b>BJ130-08020B1</b>	25	10	—	—	20	50	24	M 8×1.25-50L	19	6.6	10	38
25												
30												
<b>BJ130-08030B1</b>	30	12	—	—	30	60	28	M10×1.5 -65L	21	9	12	45
30												
40												

Part Number	H	H <sub>3</sub>	D	W	H <sub>2</sub>	W <sub>1</sub>	Clamping Force(kN)	Allowable Screw Torque(N·m)	Weight (g)
<b>BJ130-08020B1</b>	39	25	22	10	12	6	15	38	175
12							33	185	
10							30	190	
13							38	315	
<b>BJ130-10030B1</b>	54	30	25	12	15	8	13	38	315
10							32	330	

Part Number	H <sub>1</sub>	S (Clamping Stroke)	M	L <sub>2</sub>	R	W <sub>2</sub>	L	M <sub>1</sub>	L <sub>1</sub> (max)	d	H <sub>4</sub>	P		
BJ130-12040B1	40	15	—	—	40	75	35	M12×1.75-80L	25	11	14	55		
BJ130-12050B1					50				23					
BJ130-12060B1					60				25					
BJ130-12140B1					31				40				23	
BJ130-12150B1					38				50					
BJ130-12160B1					46				60					
BJ130-16040B1	40	15	—	—	40	85	42	M16×2 -85L	25	13	16	65		
BJ130-16050B1					50									
BJ130-16060B1					60									
BJ130-16150B1					38								50	
BJ130-16160B1					46								60	

Part Number	H	H <sub>3</sub>	D	W	H <sub>2</sub>	W <sub>1</sub>	Clamping Force(kN)	Allowable Screw Torque(N·m)	Weight (g)
BJ130-12040B1	67	40	32	18	16	10	18	60	595
BJ130-12050B1	69				18		50	650	
BJ130-12060B1	67				16		46	675	
BJ130-12140B1	69				18		60	585	
BJ130-12150B1	69				14		50	640	
BJ130-12160B1	69				12		46	665	
BJ130-16040B1	76	40	36	22	21	14	38	170	930
BJ130-16050B1							31	150	980
BJ130-16060B1							26	130	1025
BJ130-16150B1							31	150	965
BJ130-16160B1							26	130	1010

### Feature

Perfect for low-height clamping.

### Note

Please put grease on sliding surface to prevent galling when using in dry condition.

### How To Use

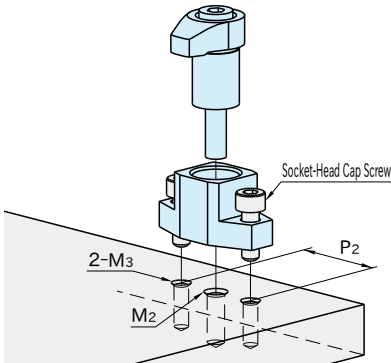

Part Number	M <sub>2</sub>	M <sub>3</sub>	P <sub>2</sub>
BJ130-08020B1	M 8×1.25 Depth 20	M 6×1	38
BJ130-08025B1			
BJ130-08030B1			
BJ130-10030B1	M10×1.5 Depth 21	M 8×1.25	45
BJ130-10040B1			
BJ130-12040B1	M12×1.75 Depth 25	M10×1.5	55
BJ130-12050B1			
BJ130-12060B1			
BJ130-12140B1			
BJ130-12150B1			
BJ130-12160B1			
BJ130-16040B1	M16×2 Depth 25	M12×1.75	65
BJ130-16050B1			
BJ130-16060B1			
BJ130-16150B1			
BJ130-16160B1			