

CP730

ONE-TOUCH FLEX LOCATOR CLAMPERS (Hexagon Head)



CP730-LH
(Tapered)

CP730-SH
(Straight)

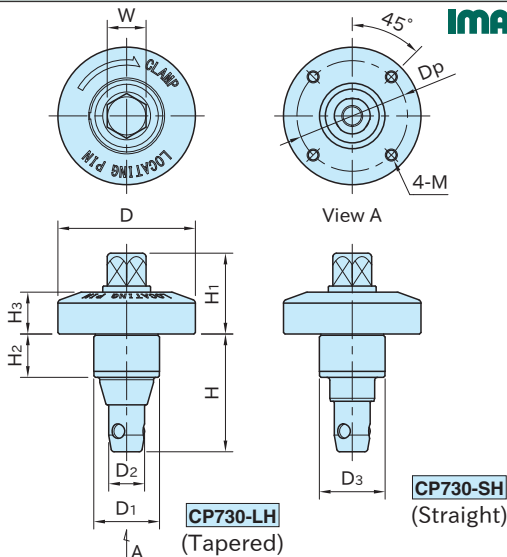

Body	Clamping Screw	Ball
SCM440 steel ISONITE Treated (Nitrocarburized)	SCM435 steel Black oxide finished Quenched & tempered	SUJ2 steel

Part Number	D ₁ (g6)	D ₃ (-0.02/-0.06)	H ₂	D	H ₁	H ₃	D ₂	H	W	M	D _p
CP730-0939LH	18	—	9.5	39	22	12	9	30	10	M4×0.7 Depth 6	30
CP730-0939SH	—	18									
CP730-1246LH	22	—									
CP730-1246SH	—	22	14.5	46	27	14	12	40	13	M5×0.8 Depth 7	37
CP730-1656LH	28	—									
CP730-1656SH	—	28	19.5	56	34	16	16	51	17	45	

Part Number	Clamping Force (N)	Allowable Screw Torque (N·m*)	Weight (g)	Proper Bushing
CP730-0939LH	1700	2	134	CP735-0939L
CP730-0939SH			133	CP735-0939S
CP730-1246LH	3000	4	241	CP735-1246L
CP730-1246SH			239	CP735-1246S
CP730-1656LH	4500	7	457	CP735-1656L
CP730-1656SH			453	CP735-1656S

*)Do not apply greater torque than allowable screw torque.
Do not use a power tool (impact wrench etc.) to turn the hex head, for damage prevention.

How To Use

■ Mounting Hole Dimension

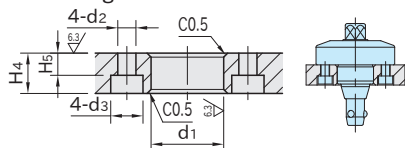

Supplied With

- **CP730-0939**: Four pieces of hex. socket-head cap screws M4×0.7-10L
- **CP730-1246**: Four pieces of hex. socket-head cap screws M4×0.7-15L
- **CP730-1656**: Four pieces of hex. socket-head cap screws M5×0.8-20L

Size	d ₁ (H7)	H ₄ (±0.05)	d ₂	H ₅	d ₃
CP730-0939	18	10	4.5	5	8
CP730-1246	22	15		10	
CP730-1656	28	20	5.5	14	10

Reference

How To Use ONE-TOUCH FLEX LOCATORS (Hexagon Head / Cam Handle)

Related Product

CP-TCW ADJUSTABLE-TORQUE WRENCHES are available for tightening.