

# AMWPD-X

# CLAMPING PINS

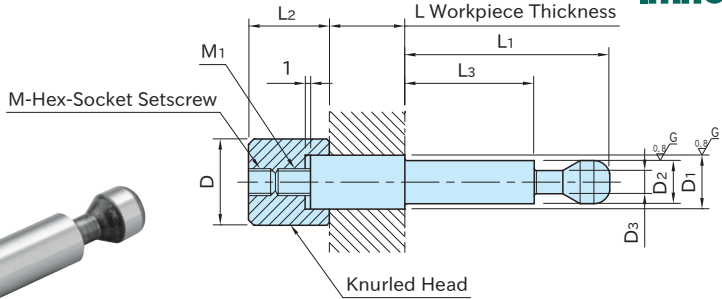

Note: L dimension is adjustable by  $\pm 1$  mm to fit actual workpiece thickness.

Shank	Head
Steel (SCM435) Induction hardened (taper seat) Precision ground	Steel (S45C) Quenched and tempered Black oxide finish

Part Number	D <sub>2</sub> (f7)	D <sub>1</sub> (f7)	L <sup>*</sup> (By 0.1mm)	D	L <sub>2</sub>	L <sub>1</sub>	L <sub>3</sub>	D <sub>3</sub>	M
<b>AMWPD40- 8-</b> (L Dim. in mm)	8	8	4 ≤ L ≤ 64	16	15	38	24	4.3	M5×0.8 -5L
<b>AMWPD40-10-</b> (L Dim. in mm)		10							
<b>AMWPD63-12-</b> (L Dim. in mm)	12	12	0 < L ≤ 90	18	23	48	31.5	6.5	M8×1.25-8L
<b>AMWPD63-16-</b> (L Dim. in mm)		16		24					

Part Number	M <sub>1</sub>	Proper Pull Clamps	Weight (g)
<b>AMWPD40- 8-</b> (L Dim. in mm)	M5×0.8	AMWPD40-W	min. 30~max. 60
<b>AMWPD40-10-</b> (L Dim. in mm)			min. 31~max. 77
<b>AMWPD63-12-</b> (L Dim. in mm)	M8×1.25	AMWPD63-W	min. 70~max.160
<b>AMWPD63-16-</b> (L Dim. in mm)			min.175~max.265

\*) For ordering, specify workpiece thickness.

## How To Use

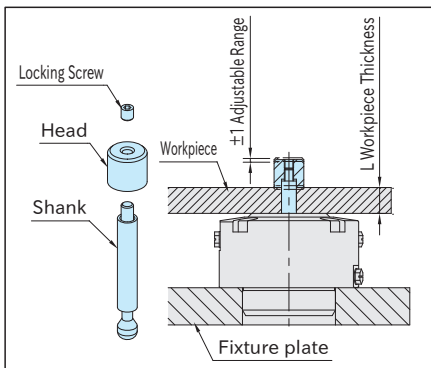

## Note

The length of L dimension should be decided depending on the workpiece thickness.

## Ordering Example

**AMWPD40-8 - 10.5**

Shank Size

L Dim.