

BJ370**PNEUMATIC WORK SUPPORTS**

Body	Piston	Locking Shaft
Aluminum (A5052) Anodized	SK95 steel Quenched & tempered Black oxide finished	S45C steel Electroless nickel plated

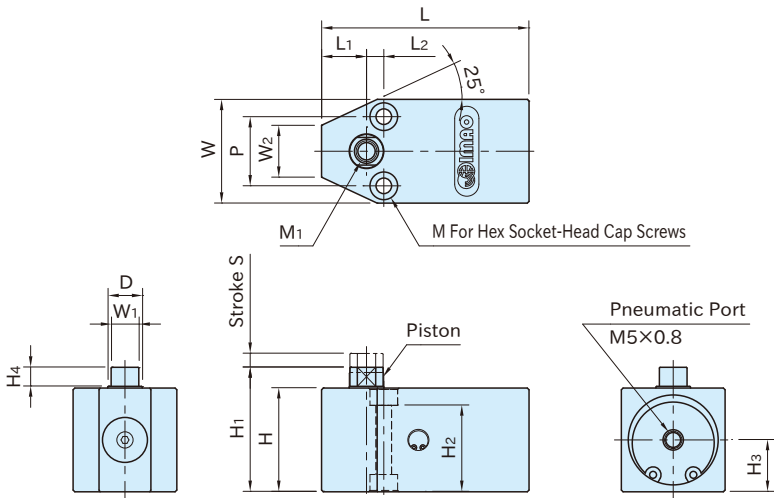

Part Number	H	H ₁	S	M ₁	D	L	W	M	H ₂	P	H ₃	W ₁	H ₄
BJ370-05001	25	30	3	M5×0.8 Depth10	8	50	25	M3	21	16	12.5	7	4.5
BJ370-06001	30	36	4	M6×1.0 Depth12	10	60	30	M4	25	20	15	8	5.5

Part Number	L ₁	L ₂	W ₂	Operating Air Pressure (MPa)	Support Capacity (N)	Piston Spring Force (N)	Weight (g)
BJ370-05001	11	4	12	0.3~1.0	300~500	1~1.9	92
BJ370-06001	13	5	15	0.3~1.0	500~700	1~2.2	165

Features

The piston can be locked/unlocked by air operation.

How To Use

■ Operating Instructions

1. Load a workpiece on the support.
2. The piston strokes to fit the workpiece by the inner spring.
3. Clamp the workpiece.
4. Apply air to the pneumatic port.
5. The piston is locked.
6. The piston is unlocked when the air pressure is released.

■ Installation Instructions

Can be mounted on both top surface and bottom surface of plate with hex-socket head cap screws.

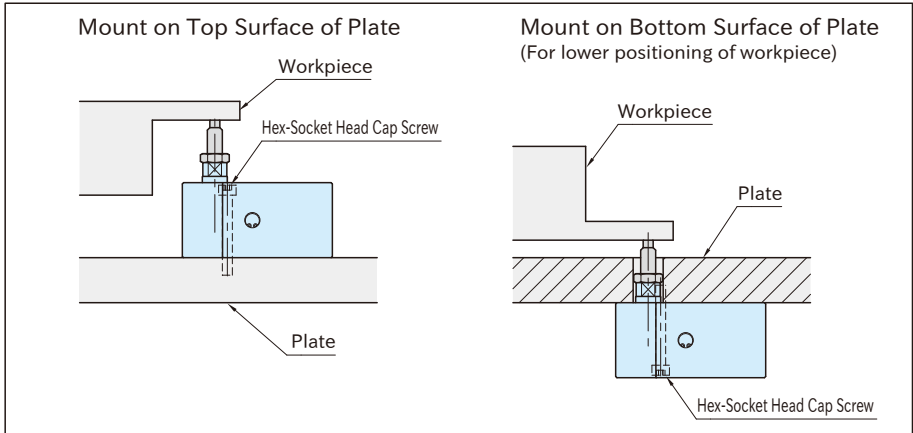

Performance Curve

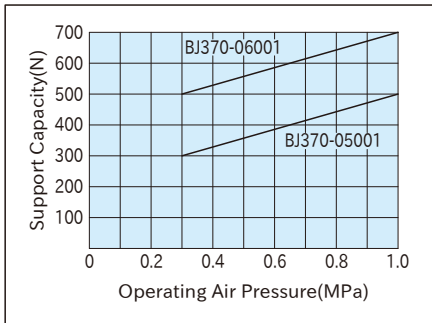

Notes:

When installing a tip on the piston, lock the piston using a wrench to prevent it from receiving any torque.

