

MAU5040-PS01 POSITIONING PLATE

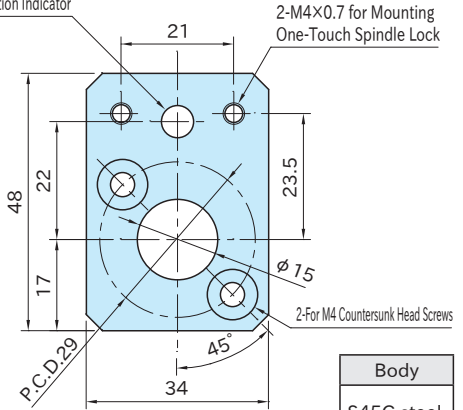

$\phi 6$ for Mounting Position Indicator

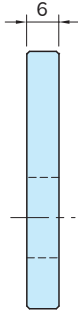

Body
S45C steel Chrome plated

Part Number	Weight (g)
MAU5040-PS01	63

Feature

Enables to change the orientation of One-Touch Spindle Locks and Digital Position Indicators for every 90 degrees.

Supplied With

2 of M4x0.7-10L Hex Socket Countersunk Head Screw

How To Use

Mount Positioning Plate to the End Plate of actuators with the included hex-socket countersunk head screws.

Note

Can not be used with [MAU3222**](#).

