

MAU5040SS

MECHANICAL LINEAR ACTUATORS

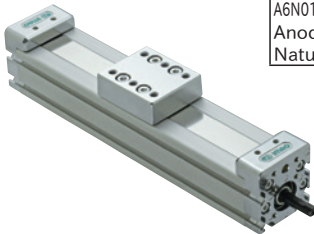

Body	Carriage End Plates	Shaft	Trapezoidal Nut	Screw	Dustproof Sheet
A6N01 aluminum Anodized Natural	ZDC2 die-cast zinc Chrome plated	S45C steel Black oxide finish	CAC902 copper alloy	SCM435 steel Trivalent chromate	SUS304H stainless steel

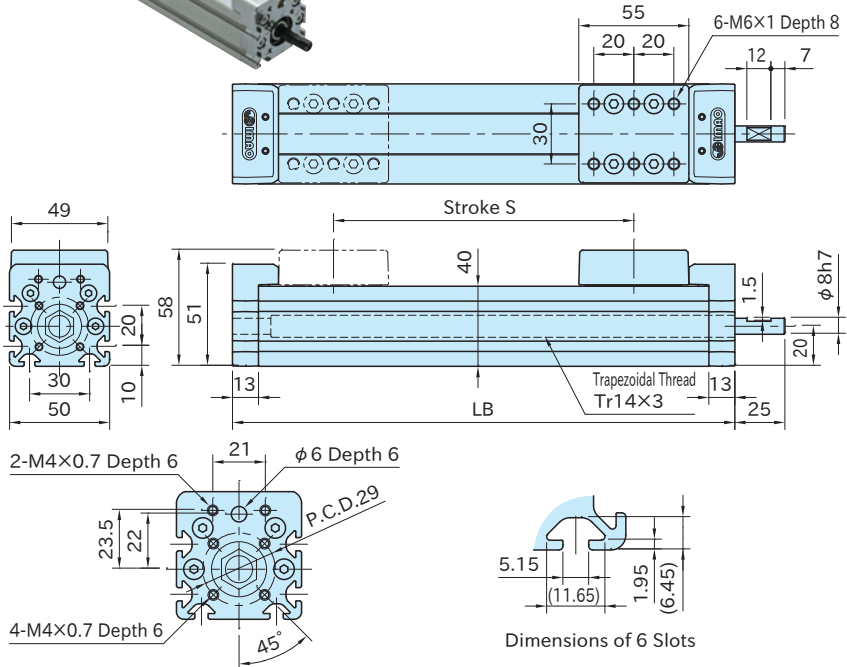

Dimensions of End Plate (Both ends)

Dimensions of 6 Slots

Part Number	Rotative Direction	S	LB	Weight (kg)
MAU5040SS-100R	CW	100	201	1.5
MAU5040SS-100L	CCW	100	201	1.5
MAU5040SS-150R	CW	150	251	1.7
MAU5040SS-150L	CCW	150	251	1.7
MAU5040SS-200R	CW	200	301	1.9
MAU5040SS-200L	CCW	200	301	1.9
MAU5040SS-250R	CW	250	351	2.1
MAU5040SS-250L	CCW	250	351	2.1
MAU5040SS-300R	CW	300	401	2.3
MAU5040SS-300L	CCW	300	401	2.3

Related Product

Choose the optional elements for your needs.

- For actuators with customized stroke, see [MAUX5040SS](#).
- One-Touch Spindle Locks
- Positioning Plate
- Digital Position Indicators
- Adapter Shafts
- Handwheels
- Pair of Stops
- T-Nuts
- Groove Cover

How To Use

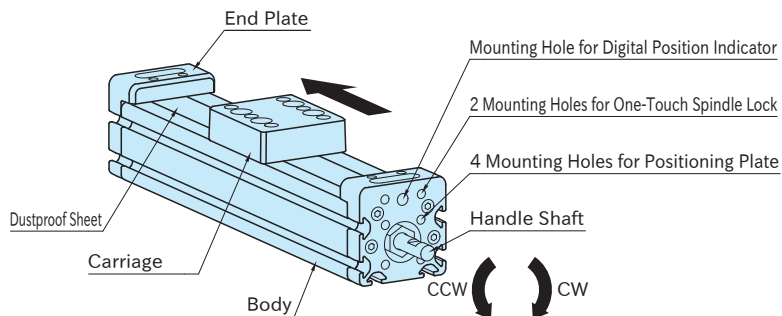

- **MAU5040SS-R**: Carriage moves toward the arrow direction by turning the Handle Shaft clockwise.
- **MAU5040SS-L**: Carriage moves toward the arrow direction by turning the Handle Shaft counterclockwise.
- Carriage moves 3mm per rotation of the Handle Shaft.

■ Horizontal Use

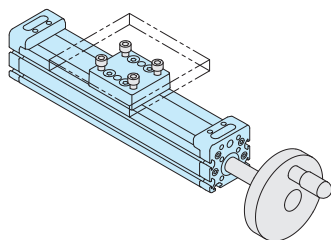

■ Vertical Use

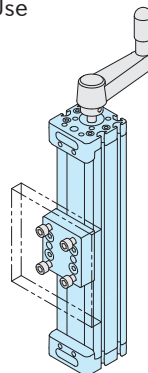

Reference

Technical Information of Mechanical Linear Actuators