

CP151

CLAMPING MODULES (Double)



CP151 -06050



CP151 -08080, 12125, 16160

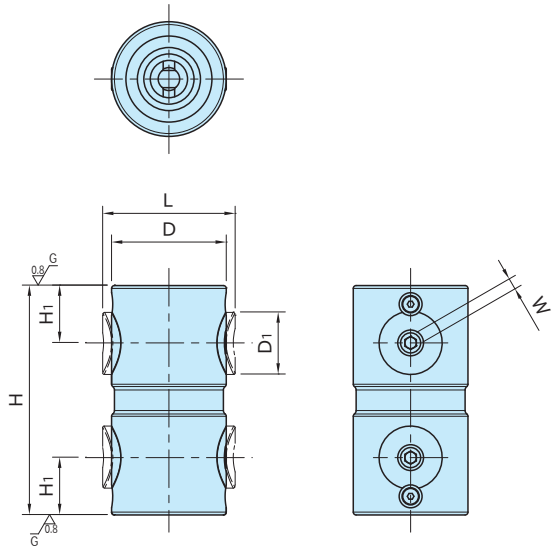

Body	Clamping Nut	Locking Screw
SCM440 steel Induction hardened Black oxide finished Precision ground	SCM440 steel Quenched and tempered Black oxide finished	SCM435 steel Quenched and tempered Black oxide finished

Part Number	D	H (±0.01)	D ₁	L	H ₁	W	Clamping Force (kN)	Allowable Screw Torque (N·m)	Weight (kg)
CP151-06050	30	50	15	34.5	12.5	3	5	4	0.2
CP151-08080	40	80	22	46	20	4	8	8	0.7
CP151-12125	60	125	32	69	30	6	15	22	2.6
CP151-16160	80	160	44	91	40	8	25	50	5.8

Related Product

- [CP150](#) Clamping Modules (Flanged)
- [CP152](#) Clamping Modules (Single)
- [CP155-L](#) Tapered Clamping Screws (Round)
- [CP155-D](#) Tapered Clamping Screws (Diamond)
- [CP156](#) Clamping Screws

Technical Information

Allowable Cutting Force & Workpiece Weight of
CLAMPING MODULES

How To Use

- Use **CP155-L** Tapered Clamping Screw (Round) for precise locating.
- Use **CP156** Clamping Screw just for fixing.

■ Mounting-Hole Dimension

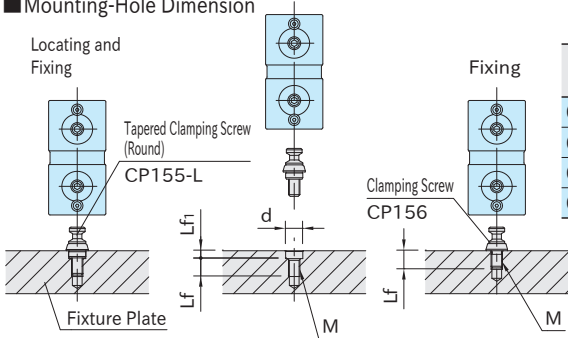

Part Number	d (H7)	Lf	Lf ₁	M
CP151-06050	8	9	5.5	M 6×1
CP151-08080	12	13	5.5	M 8×1.25
CP151-12125	18	19	6.5	M12×1.75
CP151-16160	22	23	8	M16×2

Note: Only tapped hole is required for CP156 Clamping Screw.

■ Spacing Tolerance

Spacing tolerance for CP155-L Tapered Clamping Screws (Accurate) should be ± 0.02 .

*) Spacing tolerance for CP156 Clamping Screws should be ± 0.2 .

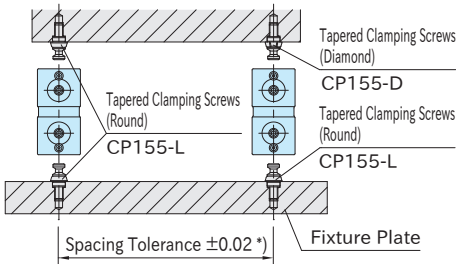

■ Coupling with Other Clamping Modules

Can be coupled with each Clamping Module. (Locating Repeatability is 0.2)

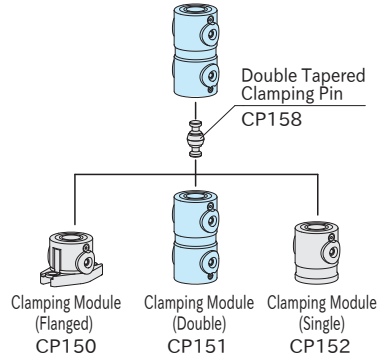

■ Tightening Order

Tighten the locking screws in order of 1(Round Tapered Clamping Screw)→2(Diamond Tapered Clamping Screw)→3(Clamping Screw)→4(Clamping Screw).

Note: For **CP151**-06050, use 2 pieces of Round Tapered Clamping Screw.

Tighten these 2 screws in the same order to maintain the locating repeatability.

