

CP726

FLEX LOCATOR BUSHINGS (Through)

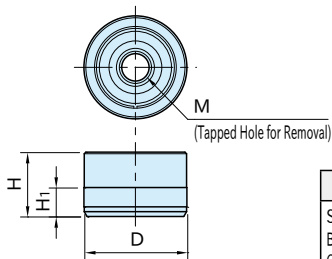

Body	Tapered Bushing
SCM440 steel Black Oxide Finished Quenched & Tempered	SCM440 steel Nitrocarburized

Part Number	D	H	H ₁	M	Lifting Force (N)*	Weight (g)
CP726-12025	25 (+0.028/-0.018)	16	8	M 8X1.25 (Prepared Hole φ 6.8)	540	46
CP726-15032	32 (+0.031/+0.021)	20	9	M10X1.5 (Prepared Hole φ 8.5)	600	92
CP726-20045	45 (+0.031/+0.021)	26	11	M14X1.5 (Prepared Hole φ 12.5)	780	230

* The lifting force is the power of the inner spring of the body to push up the movable tapered bushing.

How To Use

■ Mounting Hole Dimension for Press Fit

Installation of the Bushings on the Base Plate

Installation of the Bushings on the Fixture Plate

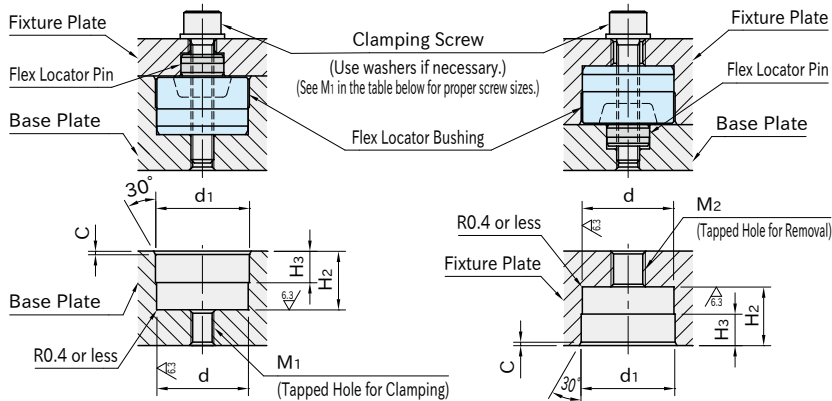

■ Spacing Tolerance

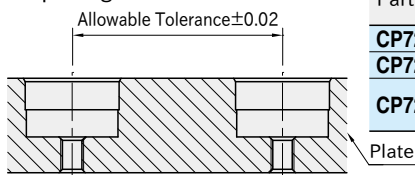

Part Number	d (H6)	H ₂ (±0.05)	d ₁	H ₃	C	M ₁	M ₂
CP726-12025	25	16.5	25.2	8	1	M 6X1	M10X1.5
CP726-15032	32	20.5	32.2	11	1.2	M 8X1.25	M12X1.75
CP726-20045	45	26.5	45.2	15	1.5	M10X1.5 M12X1.75	M16X2

Reference

- How To Install FLEX LOCATORS (Through)
- How To Use FLEX LOCATORS (Through)