

# CP727

# ONE-TOUCH FLEX LOCATOR BUSHINGS

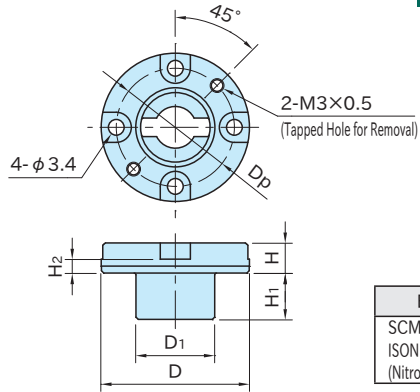

Body
SCM440 steel
ISONITE Treated
(Nitrocarburized)

Part Number	D (g6)	H	D <sub>1</sub>	H <sub>1</sub>	H <sub>2</sub>	D <sub>p</sub>	Weight (g)
CP727-0632R	28	5.5	12.5	8	2	21.5	20
CP727-0840R	32	6.5	17	10	3	25.5	32

## How To Use

### ■ Mounting Hole Dimension

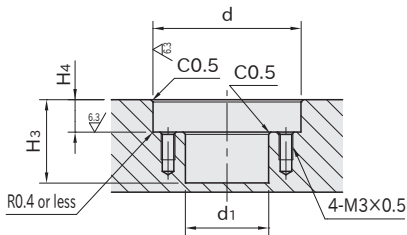

Part Number	d (H7)	H <sub>4</sub> (±0.05)	d <sub>1</sub>	H <sub>3</sub>
CP727-0632R	28	6	13.5	15
CP727-0840R	32	7	18	18

### ■ Spacing Tolerance

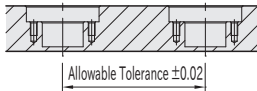

### ■ How to Remove

Insert screws into the tapped holes to lift up the bushing for removal.

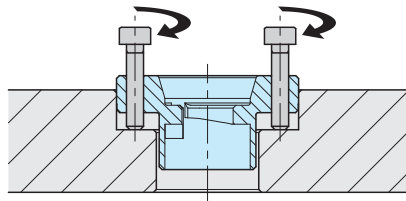

## Related Product

- [CP722](#) ONE-TOUCH FLEX LOCATOR CLAMPERS
- [CP723](#) ONE-TOUCH FLEX LOCATOR CLAMPERS(Knob)

## Reference

How To Use ONE-TOUCH FLEX LOCATORS  
(Handle / Knob)